



DPDK

DATA PLANE DEVELOPMENT KIT

Platform Specific Guides

Release 20.02.1

May 18, 2020

1 Mellanox BlueField Board Support Package	2
1.1 Supported BlueField family SoCs	2
1.2 Supported BlueField Platforms	2
1.3 Common Offload HW Drivers	2
1.4 Steps To Setup Platform	2
1.5 Compile DPDK	3
2 NXP QorIQ DPAA Board Support Package	5
2.1 Supported DPAA SoCs	5
2.2 Common Offload HW Block Drivers	5
2.3 Steps To Setup Platform	5
3 NXP QorIQ DPAA2 Board Support Package	7
3.1 Supported DPAA2 SoCs	7
3.2 Common Offload HW Block Drivers	7
3.3 Steps To Setup Platform	7
4 OCTEON TX Board Support Package	9
4.1 Common Offload HW Block Drivers	9
4.2 Steps To Setup Platform	9
4.3 Setup Platform Using OCTEON TX SDK	10
5 Marvell OCTEON TX2 Platform Guide	12
5.1 Supported OCTEON TX2 SoCs	12
5.2 OCTEON TX2 Resource Virtualization Unit architecture	12
5.3 LBK HW Access	13
5.4 SDP interface	14
5.5 OCTEON TX2 packet flow	14
5.6 HW Offload Drivers	14
5.7 Procedure to Setup Platform	15
5.8 Debugging Options	16
5.9 Compile DPDK	19

The following are platform specific guides and setup information.

MELLANOX BLUEFIELD BOARD SUPPORT PACKAGE

This document has information about steps to setup Mellanox BlueField platform and common offload HW drivers of **Mellanox BlueField** family SoC.

1.1 Supported BlueField family SoCs

- BlueField

1.2 Supported BlueField Platforms

- BlueField SmartNIC
- BlueField Reference Platforms
- BlueField Controller Card

1.3 Common Offload HW Drivers

1. NIC Driver

See `./nics/mlx5` for Mellanox mlx5 NIC driver information.

2. Cryptodev Driver

This is based on the crypto extension support of armv8. See `./cryptodevs/armv8` for armv8 crypto driver information.

Note: BlueField has a variant having no armv8 crypto extension support.

1.4 Steps To Setup Platform

Toolchains, OS and drivers can be downloaded and installed individually from the Web. But it is recommended to follow instructions at [Mellanox BlueField Software Website](#).

1.5 Compile DPDK

DPDK can be compiled either natively on BlueField platforms or cross-compiled on an x86 based platform.

1.5.1 Native Compilation

Refer to `../nics/mlx5` for prerequisites. Either Mellanox OFED/EN or rdma-core library with corresponding kernel drivers is required.

make build

```
make config T=arm64-bluefield-linux-gcc
make -j
```

meson build

```
meson build
ninja -C build
```

1.5.2 Cross Compilation

Refer to `../linux_gsg/cross_build_dpdk_for_arm64` to install the cross toolchain for ARM64. Base on that, additional header files and libraries are required:

- libibverbs
- libmlx5
- libnl-3
- libnl-route-3

Such header files and libraries can be cross-compiled and installed on to the cross toolchain directory like depicted in `arm_cross_build_getting_the_prerequisite_library`, but those can also be simply copied from the filesystem of a working BlueField platform. The following script can be run on a BlueField platform in order to create a supplementary tarball for the cross toolchain.

```
mkdir -p aarch64-linux-gnu/libc
pushd $PWD
cd aarch64-linux-gnu/libc

# Copy libraries
mkdir -p lib64
cp -a /lib64/libibverbs* lib64/
cp -a /lib64/libmlx5* lib64/
cp -a /lib64/libnl-3* lib64/
cp -a /lib64/libnl-route-3* lib64/

# Copy header files
mkdir -p usr/include/infiniband
cp -a /usr/include/infiniband/ib_user_ioctl_verbs.h usr/include/infiniband/
cp -a /usr/include/infiniband/mlx5*.h usr/include/infiniband/
cp -a /usr/include/infiniband/tm_types.h usr/include/infiniband/
cp -a /usr/include/infiniband/verbs*.h usr/include/infiniband/
```

```
# Create supplementary tarball
popd
tar cf aarch64-linux-gnu-mlx.tar aarch64-linux-gnu/
```

Then, untar the tarball at the cross toolchain directory on the x86 host.

```
cd $(dirname $(which aarch64-linux-gnu-gcc))/..
tar xf aarch64-linux-gnu-mlx.tar
```

make build

```
make config T=arm64-bluefield-linux-gcc
make -j CROSS=aarch64-linux-gnu- CONFIG_RTE_KNI_KMOD=n CONFIG_RTE_EAL_IGB_UIO=n
```

meson build

```
meson build --cross-file config/arm/arm64_bluefield_linux_gcc
ninja -C build
```

NXP QORIQ DPAA BOARD SUPPORT PACKAGE

This doc has information about steps to setup QorIQ dpaa based layerscape platform and information about common offload hw block drivers of **NXP QorIQ DPAA** SoC family.

2.1 Supported DPAA SoCs

- LS1046A/LS1026A
- LS1043A/LS1023A

More information about SoC can be found at [NXP Official Website](#).

2.2 Common Offload HW Block Drivers

1. Nics Driver

See `./nics/dpaa` for NXP dpaa nic driver information.

2. Cryptodev Driver

See `./cryptodevs/dpaa_sec` for NXP dpaa cryptodev driver information.

3. Eventdev Driver

See `./eventdevs/dpaa` for NXP dpaa eventdev driver information.

2.3 Steps To Setup Platform

There are four main pre-requisites for executing DPAA PMD on a DPAA compatible board:

1. ARM 64 Tool Chain

For example, the `*aarch64*` [Linaro Toolchain](#).

2. Linux Kernel

It can be obtained from [NXP's Github hosting](#).

3. Rootfile system

Any `aarch64` supporting filesystem can be used. For example, Ubuntu 16.04 LTS (Xenial) or 18.04 (Bionic) userland which can be obtained from [here](#).

4. FMC Tool

Before any DPDK application can be executed, the Frame Manager Configuration Tool (FMC) need to be executed to set the configurations of the queues. This includes the queue state, RSS and other policies. This tool can be obtained from [NXP \(Freescale\) Public Git Repository](#).

This tool needs configuration files which are available in the *DPDK Extra Scripts*, described below for DPDK usages.

As an alternative method, DPAA PMD can also be executed using images provided as part of SDK from NXP. The SDK includes all the above prerequisites necessary to bring up a DPAA board.

The following dependencies are not part of DPDK and must be installed separately:

- **NXP Linux SDK**

NXP Linux software development kit (SDK) includes support for family of QorIQ® ARM-Architecture-based system on chip (SoC) processors and corresponding boards.

It includes the Linux board support packages (BSPs) for NXP SoCs, a fully operational tool chain, kernel and board specific modules.

SDK and related information can be obtained from: [NXP QorIQ SDK](#).

- **DPDK Extra Scripts**

DPAA based resources can be configured easily with the help of ready scripts as provided in the DPDK Extra repository.

[DPDK Extras Scripts](#).

Currently supported by DPDK:

- NXP SDK **2.0+** (preferred: LSDK 18.09).
- Supported architectures: **arm64 LE**.
- Follow the DPDK Getting Started Guide for Linux to setup the basic DPDK environment.

NXP QORIQ DPAA2 BOARD SUPPORT PACKAGE

This doc has information about steps to setup NXP QorIQ DPAA2 platform and information about common offload hw block drivers of NXP QorIQ DPAA2 SoC family.

3.1 Supported DPAA2 SoCs

- LX2160A
- LS2084A/LS2044A
- LS2088A/LS2048A
- LS1088A/LS1048A

More information about SoC can be found at [NXP Official Website](#).

3.2 Common Offload HW Block Drivers

1. Nics Driver

See `./nics/dpaa2` for NXP dpaa2 nic driver information.

2. Cryptodev Driver

See `./cryptodevs/dpaa2_sec` for NXP dpaa2 cryptodev driver information.

3. Eventdev Driver

See `./eventdevs/dpaa2` for NXP dpaa2 eventdev driver information.

4. Rawdev AIOP CMDIF Driver

See `./rawdevs/dpaa2_cmdif` for NXP dpaa2 AIOP command interface driver information.

5. Rawdev QDMA Driver

See `./rawdevs/dpaa2_qdma` for NXP dpaa2 QDMA driver information.

3.3 Steps To Setup Platform

There are four main pre-requisites for executing DPAA2 PMD on a DPAA2 compatible board:

1. ARM 64 Tool Chain

For example, the [*aarch64* Linaro Toolchain](#).

2. Linux Kernel

It can be obtained from [NXP's Github hosting](#).

3. Rootfile system

Any *aarch64* supporting filesystem can be used. For example, Ubuntu 16.04 LTS (Xenial) or 18.04 (Bionic) userland which can be obtained from [here](#).

4. Resource Scripts

DPAA2 based resources can be configured easily with the help of ready scripts as provided in the DPDK Extra repository.

5. Build Config

Use dpaa build configs, they work for both DPAA2 and DPAA platforms.

As an alternative method, DPAA2 PMD can also be executed using images provided as part of SDK from NXP. The SDK includes all the above prerequisites necessary to bring up a DPAA2 board.

The following dependencies are not part of DPDK and must be installed separately:

- **NXP Linux SDK**

NXP Linux software development kit (SDK) includes support for family of QorIQ® ARM-Architecture-based system on chip (SoC) processors and corresponding boards.

It includes the Linux board support packages (BSPs) for NXP SoCs, a fully operational tool chain, kernel and board specific modules.

SDK and related information can be obtained from: [NXP QorIQ SDK](#).

- **DPDK Extra Scripts**

DPAA2 based resources can be configured easily with the help of ready scripts as provided in the DPDK Extra repository.

[DPDK Extras Scripts](#).

Currently supported by DPDK:

- NXP SDK **LSDK 19.09++**.
- MC Firmware version **10.18.0** and higher.
- Supported architectures: **arm64 LE**.
- Follow the DPDK Getting Started Guide for Linux to setup the basic DPDK environment.

OCTEON TX BOARD SUPPORT PACKAGE

This doc has information about steps to setup OCTEON TX platform and information about common offload hw block drivers of **Cavium OCTEON TX** SoC family.

More information about SoC can be found at [Cavium, Inc Official Website](#).

4.1 Common Offload HW Block Drivers

1. **Crypto Driver** See `../cryptodevs/octeontx` for octeontx crypto driver information.
2. **Eventdev Driver** See `../eventdevs/octeontx` for octeontx ssovfv eventdev driver information.
3. **Mempool Driver** See `../mempool/octeontx` for octeontx fpavfv mempool driver information.

4.2 Steps To Setup Platform

There are three main pre-prerequisites for setting up Platform drivers on OCTEON TX compatible board:

1. **OCTEON TX Linux kernel PF driver for Network acceleration HW blocks**

The OCTEON TX Linux kernel drivers (includes the required PF driver for the Platform drivers) are available on Github at [octeontx-kmod](#) along with build, install and dpdk usage instructions.

Note: The PF driver and the required microcode for the crypto offload block will be available with OCTEON TX SDK only. So for using crypto offload, follow the steps mentioned in [Setup Platform Using OCTEON TX SDK](#).

2. **ARM64 Tool Chain**

For example, the *aarch64* Linaro Toolchain, which can be obtained from [here](#).

3. **Rootfile system**

Any *aarch64* supporting filesystem can be used. For example, Ubuntu 15.10 (Wily) or 16.04 LTS (Xenial) userland which can be obtained from <http://cdimage.ubuntu.com/ubuntu-base/releases/16.04/release/ubuntu-base-16.04.1-base-arm64.tar.gz>.

As an alternative method, Platform drivers can also be executed using images provided as part of SDK from Cavium. The SDK includes all the above prerequisites necessary to bring up a OCTEON TX board. Please refer [Setup Platform Using OCTEON TX SDK](#).

- Follow the DPDK `../linux_gsg/index` to setup the basic DPDK environment.

4.3 Setup Platform Using OCTEON TX SDK

The OCTEON TX platform drivers can be compiled either natively on **OCTEON TX**[®] board or cross-compiled on an x86 based platform.

The **OCTEON TX**[®] board must be running the linux kernel based on OCTEON TX SDK 6.2.0 patch 3. In this, the PF drivers for all hardware offload blocks are already built in.

4.3.1 Native Compilation

If the kernel and modules are cross-compiled and copied to the target board, some intermediate binaries required for native build would be missing on the target board. To make sure all the required binaries are available in the native architecture, the linux sources need to be compiled once natively.

```
cd /lib/modules/$(uname -r)/source
make menuconfig
make
```

The above steps would rebuild the modules and the required intermediate binaries. Once the target is ready for native compilation, the OCTEON TX platform drivers can be compiled with the following steps,

```
cd <dpdk directory>
make config T=arm64-thunderx-linux-gcc
make
```

The example applications can be compiled using the following:

```
cd <dpdk directory>
export RTE_SDK=$PWD
export RTE_TARGET=build
cd examples/<application>
make
```

4.3.2 Cross Compilation

The DPDK applications can be cross-compiled on any x86 based platform. The OCTEON TX SDK need to be installed on the build system. The SDK package will provide the required toolchain etc.

Refer to `../linux_gsg/cross_build_dpdk_for_arm64` for further steps on compilation. The ‘host’ & ‘CC’ to be used in the commands would change, in addition to the paths to which libnuma related files have to be copied.

The following steps can be used to perform cross-compilation with OCTEON TX SDK 6.2.0 patch 3:

```
cd <sdk_install_dir>
source env-setup

git clone https://github.com/numactl/numactl.git
cd numactl
git checkout v2.0.11 -b v2.0.11
./autogen.sh
autoconf -i
./configure --host=aarch64-thunderx-linux CC=aarch64-thunderx-linux-gnu-gcc --prefix=<numa_inst
make install
```

The above steps will prepare build system with numa additions. Now this build system can be used to build applications for **OCTEON TX**® platforms.

```
cd <dppk directory>
export RTE_SDK=$PWD
export RTE_KERNELDIR=$THUNDER_ROOT/linux/kernel/linux
make config T=arm64-thunderx-linux-gcc
make -j CROSS=aarch64-thunderx-linux-gnu- CONFIG_RTE_KNI_KMOD=n CONFIG_RTE_EAL_IGB_UIO=n EXTRA_
```

If NUMA support is not required, it can be disabled as explained in `../linux_gsg/cross_build_dpdk_for_arm64`.

Following steps could be used in that case.

```
make config T=arm64-thunderx-linux-gcc
make CROSS=aarch64-thunderx-linux-gnu-
```

SDK and related information can be obtained from: [Cavium support site](#).

MARVELL OCTEON TX2 PLATFORM GUIDE

This document gives an overview of **Marvell OCTEON TX2** RVU H/W block, packet flow and procedure to build DPDK on OCTEON TX2 platform.

More information about OCTEON TX2 SoC can be found at [Marvell Official Website](#).

5.1 Supported OCTEON TX2 SoCs

- CN96xx
- CN93xx

5.2 OCTEON TX2 Resource Virtualization Unit architecture

The Fig. 5.1 diagram depicts the RVU architecture and a resource provisioning example.

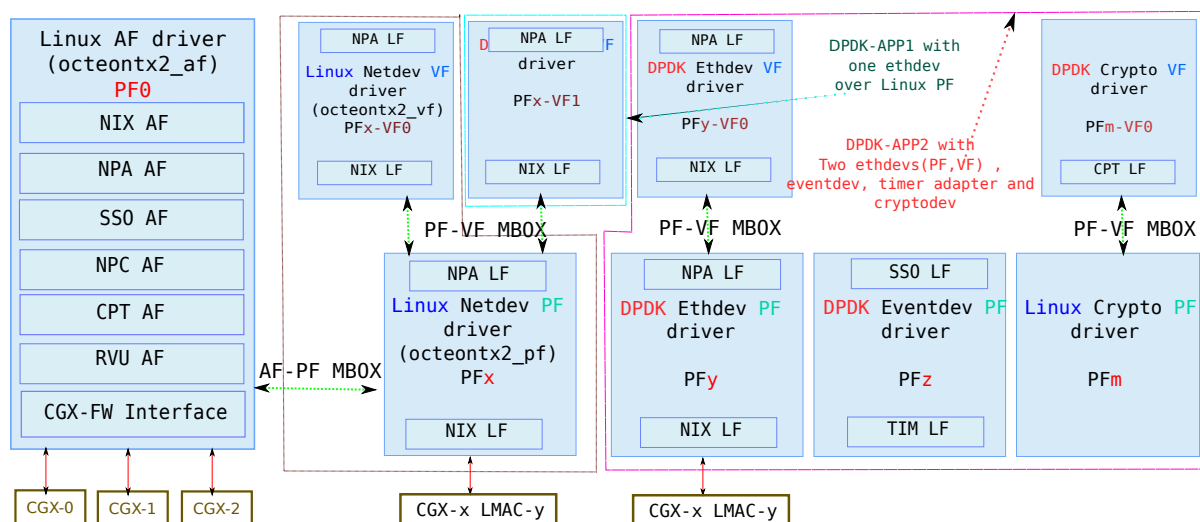

Fig. 5.1: OCTEON TX2 Resource virtualization architecture and provisioning example

Resource Virtualization Unit (RVU) on Marvell's OCTEON TX2 SoC maps HW resources belonging to the network, crypto and other functional blocks onto PCI-compatible physical and virtual functions.

Each functional block has multiple local functions (LFs) for provisioning to different PCIe devices. RVU supports multiple PCIe SRIOV physical functions (PFs) and virtual functions (VFs).

The [Table 5.1](#) shows the various local functions (LFs) provided by the RVU and its functional mapping to DPDK subsystem.

Table 5.1: RVU managed functional blocks and its mapping to DPDK subsystem

#	LF	DPDK subsystem mapping
1	NIX	rte_ethdev, rte_tm, rte_event_eth_[rt]x_adapter, rte_security
2	NPA	rte_mempool
3	NPC	rte_flow
4	CPT	rte_cryptodev, rte_event_crypto_adapter
5	SSO	rte_eventdev
6	TIM	rte_event_timer_adapter
7	LBK	rte_ethdev
8	DPI	rte_rawdev
9	SDP	rte_ethdev

PF0 is called the administrative / admin function (AF) and has exclusive privileges to provision RVU functional block's LFs to each of the PF/VF.

PF/VFs communicates with AF via a shared memory region (mailbox). Upon receiving requests from PF/VF, AF does resource provisioning and other HW configuration.

AF is always attached to host, but PF/VFs may be used by host kernel itself, or attached to VMs or to userspace applications like DPDK, etc. So, AF has to handle provisioning/configuration requests sent by any device from any domain.

The AF driver does not receive or process any data. It is only a configuration driver used in control path.

The [Fig. 5.1](#) diagram also shows a resource provisioning example where,

1. PFx and PFx-VF0 bound to Linux netdev driver.
2. PFx-VF1 ethdev driver bound to the first DPDK application.
3. PFy ethdev driver, PFy-VF0 ethdev driver, PFz eventdev driver, PFm-VF0 cryptodev driver bound to the second DPDK application.

5.3 LBK HW Access

Loopback HW Unit (LBK) receives packets from NIX-RX and sends packets back to NIX-TX. The loopback block has N channels and contains data buffering that is shared across all channels. The LBK HW Unit is abstracted using ethdev subsystem, Where PF0's VFs are exposed as ethdev device and odd-even pairs of VFs are tied together, that is, packets sent on odd VF end up received on even VF and vice versa. This would enable HW accelerated means of communication between two domains where even VF bound to the first domain and odd VF bound to the second domain.

Typical application usage models are,

1. Communication between the Linux kernel and DPDK application.
2. Exception path to Linux kernel from DPDK application as SW KNI replacement.
3. Communication between two different DPDK applications.

5.4 SDP interface

System DPI Packet Interface unit(SDP) provides PCIe endpoint support for remote host to DMA packets into and out of OCTEON TX2 SoC. SDP interface comes in to live only when OCTEON TX2 SoC is connected in PCIe endpoint mode. It can be used to send/receive packets to/from remote host machine using input/output queue pairs exposed to it. SDP interface receives input packets from remote host from NIX-RX and sends packets to remote host using NIX-TX. Remote host machine need to use corresponding driver (kernel/user mode) to communicate with SDP interface on OCTEON TX2 SoC. SDP supports single PCIe SRIOV physical function(PF) and multiple virtual functions(VF's). Users can bind PF or VF to use SDP interface and it will be enumerated as ethdev ports.

The primary use case for SDP is to enable the smart NIC use case. Typical usage models are,

1. Communication channel between remote host and OCTEON TX2 SoC over PCIe.
2. Transfer packets received from network interface to remote host over PCIe and vice-versa.

5.5 OCTEON TX2 packet flow

The Fig. 5.2 diagram depicts the packet flow on OCTEON TX2 SoC in conjunction with use of various HW accelerators.

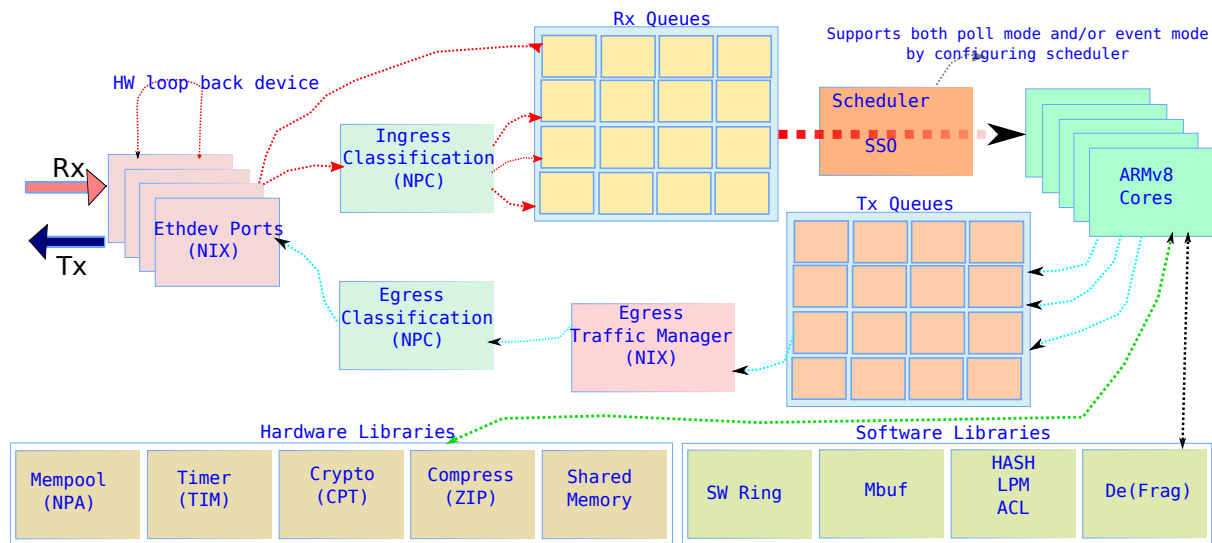

Fig. 5.2: OCTEON TX2 packet flow in conjunction with use of HW accelerators

5.6 HW Offload Drivers

This section lists dataplane H/W block(s) available in OCTEON TX2 SoC.

1. **Ethdev Driver** See `../nics/octeontx2` for NIX Ethdev driver information.
2. **Mempool Driver** See `../mempool/octeontx2` for NPA mempool driver information.
3. **Event Device Driver** See `../eventdevs/octeontx2` for SSO event device driver information.
4. **DMA Rawdev Driver** See `../rawdevs/octeontx2_dma` for DMA driver information.

5. **Crypto Device Driver** See `../cryptodevs/octeontx2` for CPT crypto device driver information.

5.7 Procedure to Setup Platform

There are three main prerequisites for setting up DPDK on OCTEON TX2 compatible board:

1. OCTEON TX2 Linux kernel driver

The dependent kernel drivers can be obtained from the kernel.org.

Alternatively, the Marvell SDK also provides the required kernel drivers.

Linux kernel should be configured with the following features enabled:

```
# 64K pages enabled for better performance
CONFIG_ARM64_64K_PAGES=y
CONFIG_ARM64_VA_BITS_48=y
# huge pages support enabled
CONFIG_HUGETLBFS=y
CONFIG_HUGETLB_PAGE=y
# VFIO enabled with TYPE1 IOMMU at minimum
CONFIG_VFIO_IOMMU_TYPE1=y
CONFIG_VFIO_VIRQFD=y
CONFIG_VFIO=y
CONFIG_VFIO_NOIOMMU=y
CONFIG_VFIO_PCI=y
CONFIG_VFIO_PCI_MMAP=y
# SMMUv3 driver
CONFIG_ARM_SMMU_V3=y
# ARMv8.1 LSE atomics
CONFIG_ARM64_LSE_ATOMICS=y
# OCTEONTX2 drivers
CONFIG_OCTEONTX2_MBOX=y
CONFIG_OCTEONTX2_AF=y
# Enable if netdev PF driver required
CONFIG_OCTEONTX2_PF=y
# Enable if netdev VF driver required
CONFIG_OCTEONTX2_VF=y
CONFIG_CRYPTO_DEV_OCTEONTX2_CPT=y
# Enable if OCTEONTX2 DMA PF driver required
CONFIG_OCTEONTX2_DPI_PF=n
```

2. ARM64 Linux Tool Chain

For example, the *aarch64* Linaro Toolchain, which can be obtained from [here](#).

Alternatively, the Marvell SDK also provides GNU GCC toolchain, which is optimized for OCTEON TX2 CPU.

3. Rootfile system

Any *aarch64* supporting filesystem may be used. For example, Ubuntu 15.10 (Wily) or 16.04 LTS (Xenial) userland which can be obtained from <http://cdimage.ubuntu.com/ubuntu-base/releases/16.04/release/ubuntu-base-16.04.1-base-arm64.tar.gz>.

Alternatively, the Marvell SDK provides the buildroot based root filesystem. The SDK includes all the above prerequisites necessary to bring up the OCTEON TX2 board.

- Follow the DPDK `../linux_gsg/index` to setup the basic DPDK environment.

5.8 Debugging Options

Table 5.2: OCTEON TX2 common debug options

#	Component	EAL log command
1	Common	<code>-log-level='pmd.octeontx2.base,8'</code>
2	Mailbox	<code>-log-level='pmd.octeontx2.mbox,8'</code>

5.8.1 Debugfs support

The **OCTEON TX2 Linux kernel driver** provides support to dump RVU blocks context or stats using debugfs.

Enable debugfs by:

1. Compile kernel with debugfs enabled, i.e `CONFIG_DEBUGFS=y`.
2. Boot OCTEON TX2 with debugfs supported kernel.
3. Verify debugfs mounted by default `"mount | grep -i debugfs"` or mount it manually by using.

```
# mount -t debugfs none /sys/kernel/debug
```

Currently debugfs supports the following RVU blocks NIX, NPA, NPC, NDC, SSO & CGX.

The file structure under `/sys/kernel/debug` is as follows

```
octeontx2/
|-- cgx
|   |-- cgx0
|   |   |-- lmac0
|   |   |   |-- stats
|   |-- cgx1
|   |   |-- lmac0
|   |   |   |-- stats
|   |   |-- lmac1
|   |   |   |-- stats
|   |-- cgx2
|   |   |-- lmac0
|   |   |   |-- stats
|-- cpt
|   |-- cpt_engines_info
|   |-- cpt_engines_sts
|   |-- cpt_err_info
|   |-- cpt_lfs_info
|   |-- cpt_pc
|---- nix
|   |-- cq_ctx
|   |-- ndc_rx_cache
|   |-- ndc_rx_hits_miss
|   |-- ndc_tx_cache
|   |-- ndc_tx_hits_miss
|   |-- qsize
|   |-- rq_ctx
|   |-- sq_ctx
|   |-- tx_stall_hwissue
|-- npa
|   |-- aura_ctx
|   |-- ndc_cache
|   |-- ndc_hits_miss
```

```

|   |-- pool_ctx
|   '-- qsize
|-- npc
|   |-- mcam_info
|   '-- rx_miss_act_stats
|-- rsrc_alloc
'-- sso
    |-- hws
    |   '-- sso_hws_info
    '-- hwgrp
        |-- sso_hwgrp_aq_thresh
        |-- sso_hwgrp_iaq_walk
        |-- sso_hwgrp_pc
        |-- sso_hwgrp_free_list_walk
        |-- sso_hwgrp_ient_walk
        '-- sso_hwgrp_taq_walk

```

RVU block LF allocation:

```
cat /sys/kernel/debug/octeontx2/rsrc_alloc
```

pcifunc	NPA	NIX	SSO GROUP	SSOWS	TIM	CPT
PF1	0	0				
PF4		1				
PF13			0, 1	0, 1	0	

CGX example usage:

```
cat /sys/kernel/debug/octeontx2/cgx/cgx2/lmac0/stats
```

```

=====Link Status=====
Link is UP 40000 Mbps
=====RX_STATS=====
Received packets: 0
Octets of received packets: 0
Received PAUSE packets: 0
Received PAUSE and control packets: 0
Filtered DMAC0 (NIX-bound) packets: 0
Filtered DMAC0 (NIX-bound) octets: 0
Packets dropped due to RX FIFO full: 0
Octets dropped due to RX FIFO full: 0
Error packets: 0
Filtered DMAC1 (NCSI-bound) packets: 0
Filtered DMAC1 (NCSI-bound) octets: 0
NCSI-bound packets dropped: 0
NCSI-bound octets dropped: 0
=====TX_STATS=====
Packets dropped due to excessive collisions: 0
Packets dropped due to excessive deferral: 0
Multiple collisions before successful transmission: 0
Single collisions before successful transmission: 0
Total octets sent on the interface: 0
Total frames sent on the interface: 0
Packets sent with an octet count < 64: 0
Packets sent with an octet count == 64: 0
Packets sent with an octet count of 65127: 0
Packets sent with an octet count of 128-255: 0
Packets sent with an octet count of 256-511: 0
Packets sent with an octet count of 512-1023: 0
Packets sent with an octet count of 1024-1518: 0
Packets sent with an octet count of > 1518: 0
Packets sent to a broadcast DMAC: 0
Packets sent to the multicast DMAC: 0
Transmit underflow and were truncated: 0

```

Control/PAUSE packets sent: 0

CPT example usage:

```
cat /sys/kernel/debug/octeonx2/cpt/cpt_pc

CPT instruction requests    0
CPT instruction latency     0
CPT NCB read requests      0
CPT NCB read latency       0
CPT read requests caused by UC fills  0
CPT active cycles pc       1395642
CPT clock count pc         5579867595493
```

NIX example usage:

```
Usage: echo <nixlf> [cq number/all] > /sys/kernel/debug/octeonx2/nix/cq_ctx
       cat /sys/kernel/debug/octeonx2/nix/cq_ctx
echo 0 0 > /sys/kernel/debug/octeonx2/nix/cq_ctx
cat /sys/kernel/debug/octeonx2/nix/cq_ctx
```

```
====cq_ctx for nixlf:0 and qidx:0 is====
W0: base                158ef1a00

W1: wrptr                0
W1: avg_con              0
W1: cint_idx             0
W1: cq_err               0
W1: qint_idx             0
W1: bpid                 0
W1: bp_ena               0

W2: update_time          31043
W2: avg_level            255
W2: head                  0
W2: tail                  0

W3: cq_err_int_ena       5
W3: cq_err_int           0
W3: qsize                 4
W3: caching               1
W3: substream            0x000
W3: ena                    1
W3: drop_ena              1
W3: drop                  64
W3: bp                     0
```

NPA example usage:

```
Usage: echo <npalf> [pool number/all] > /sys/kernel/debug/octeonx2/npa/pool_ctx
       cat /sys/kernel/debug/octeonx2/npa/pool_ctx
echo 0 0 > /sys/kernel/debug/octeonx2/npa/pool_ctx
cat /sys/kernel/debug/octeonx2/npa/pool_ctx
```

```
====POOL : 0====
W0: Stack base          1375bff00
W1: ena                  1
W1: nat_align           1
W1: stack_caching       1
W1: stack_way_mask      0
W1: buf_offset           1
W1: buf_size            19
W2: stack_max_pages     24315
W2: stack_pages         24314
W3: op_pc                267456
```

```

W4: stack_offset      2
W4: shift             5
W4: avg_level         255
W4: avg_con           0
W4: fc_ena            0
W4: fc_stype          0
W4: fc_hyst_bits      0
W4: fc_up_crossing    0
W4: update_time       62993
W5: fc_addr           0
W6: ptr_start         1593adf00
W7: ptr_end           180000000
W8: err_int           0
W8: err_int_ena       7
W8: thresh_int        0
W8: thresh_int_ena    0
W8: thresh_up         0
W8: thresh_qint_idx   0
W8: err_qint_idx      0

```

NPC example usage:

```
cat /sys/kernel/debug/octeonx2/npc/mcam_info
```

```

NPC MCAM info:
RX keywidth      : 224bits
TX keywidth      : 224bits

MCAM entries     : 2048
Reserved         : 158
Available        : 1890

MCAM counters   : 512
Reserved         : 1
Available        : 511

```

SSO example usage:

```
Usage: echo [<hws>/all] > /sys/kernel/debug/octeonx2/sso/hws/sso_hws_info
echo 0 > /sys/kernel/debug/octeonx2/sso/hws/sso_hws_info
```

```

=====
SSOW HWS[0] Arbitration State      0x0
SSOW HWS[0] Guest Machine Control  0x0
SSOW HWS[0] SET[0] Group Mask[0]  0xfffffffffffffffffff
SSOW HWS[0] SET[0] Group Mask[1]  0xfffffffffffffffffff
SSOW HWS[0] SET[0] Group Mask[2]  0xfffffffffffffffffff
SSOW HWS[0] SET[0] Group Mask[3]  0xfffffffffffffffffff
SSOW HWS[0] SET[1] Group Mask[0]  0xfffffffffffffffffff
SSOW HWS[0] SET[1] Group Mask[1]  0xfffffffffffffffffff
SSOW HWS[0] SET[1] Group Mask[2]  0xfffffffffffffffffff
SSOW HWS[0] SET[1] Group Mask[3]  0xfffffffffffffffffff
=====

```

5.9 Compile DPDK

DPDK may be compiled either natively on OCTEON TX2 platform or cross-compiled on an x86 based platform.

5.9.1 Native Compilation

make build

```
make config T=arm64-octeontx2-linux-gcc
make -j
```

The example applications can be compiled using the following:

```
cd <dpdk directory>
export RTE_SDK=$PWD
export RTE_TARGET=build
cd examples/<application>
make -j
```

meson build

```
meson build
ninja -C build
```

5.9.2 Cross Compilation

Refer to `../linux_gsg/cross_build_dpdk_for_arm64` for generic arm64 details.

make build

```
make config T=arm64-octeontx2-linux-gcc
make -j CROSS=aarch64-marvell-linux-gnu- CONFIG_RTE_KNI_KMOD=n
```

meson build

```
meson build --cross-file config/arm/arm64_octeontx2_linux_gcc
ninja -C build
```

Note: By default, meson cross compilation uses `aarch64-linux-gnu-gcc` toolchain, if Marvell toolchain is available then it can be used by overriding the `c`, `cpp`, `ar`, `strip` binaries attributes to respective Marvell toolchain binaries in `config/arm/arm64_octeontx2_linux_gcc` file.
