



DPDK
DATA PLANE DEVELOPMENT KIT

DPDK as microservices in ZTE Paas

Yong Wang
ZTE

DPDK Summit - San Jose – 2017



#DPDKSummit

Overview:ZTE Paas

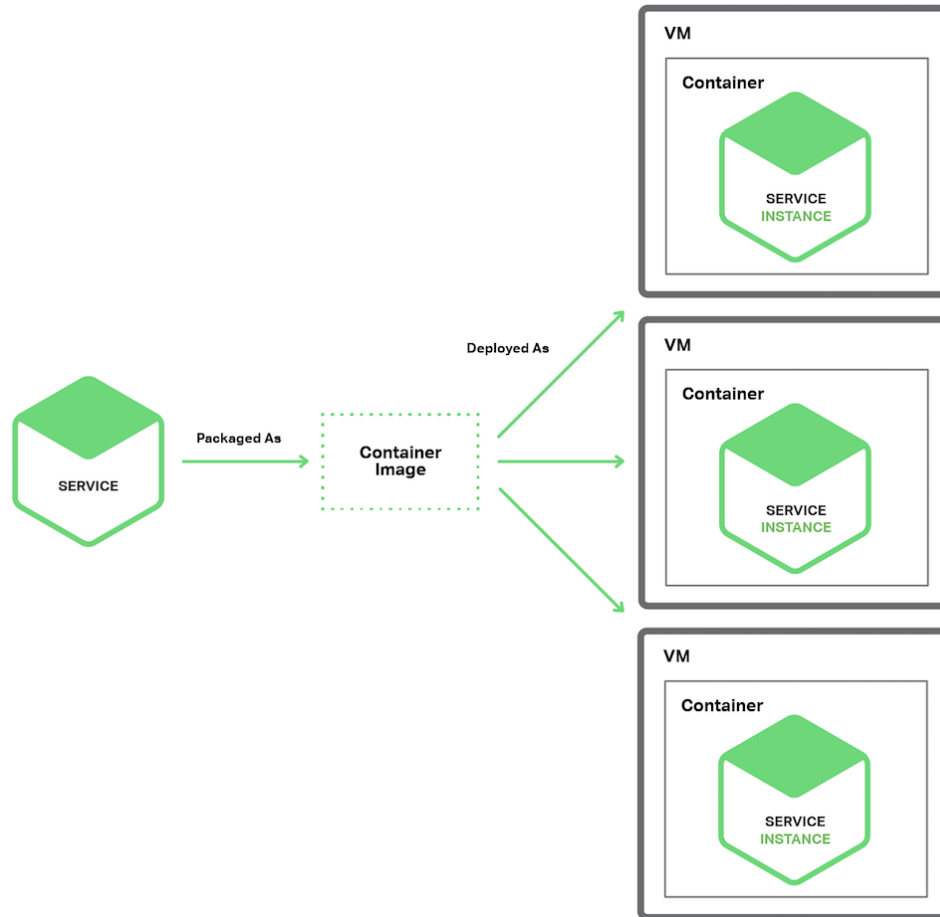

- ◆ run in docker, deployed in vm or ironic
- ◆ implement service discovery mechanism
- ◆ support ICT applications
- ◆ multi-tenant, multi-networking-plane

Packet Flow to/from PaaS

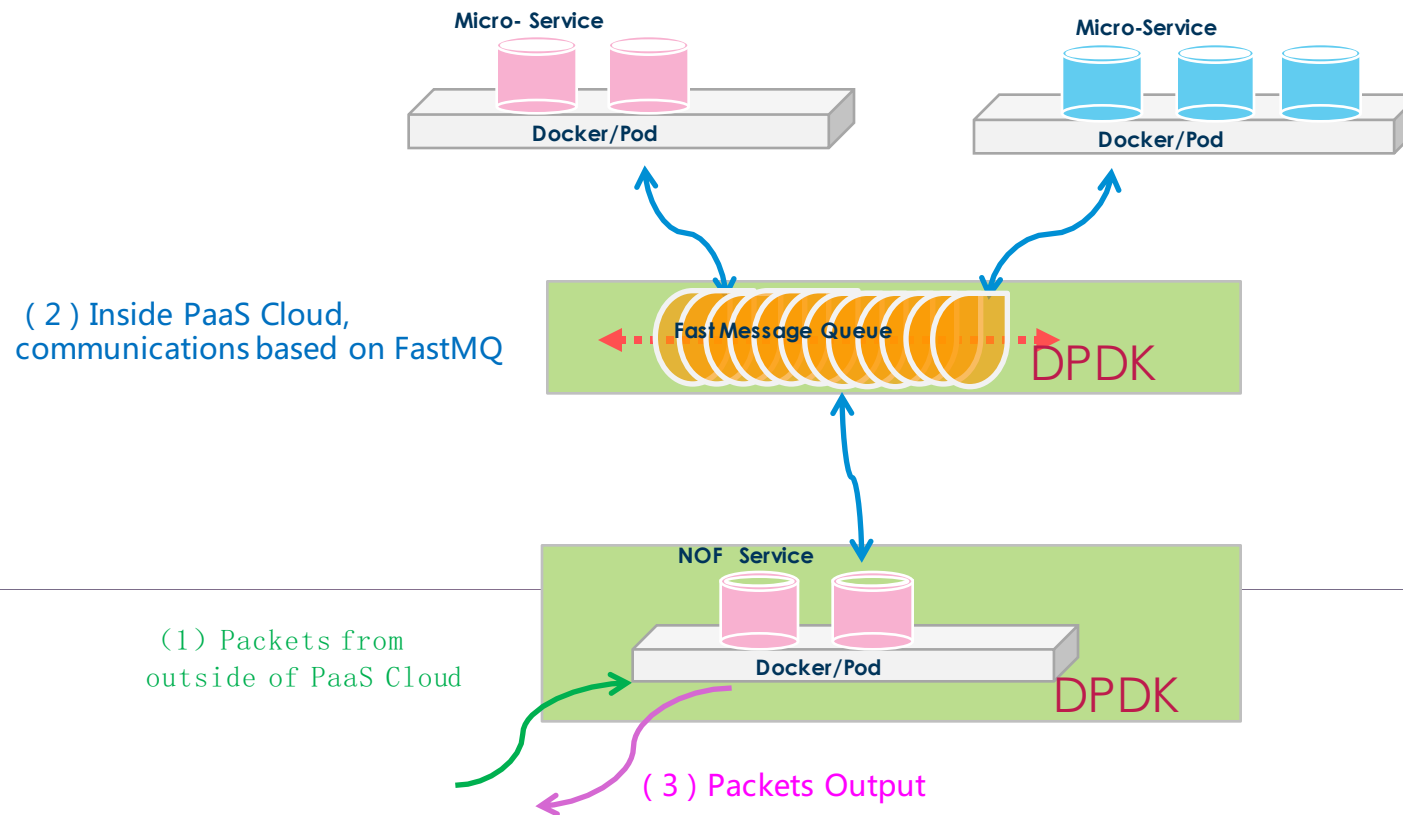

Message Service--Publish/Subscribe

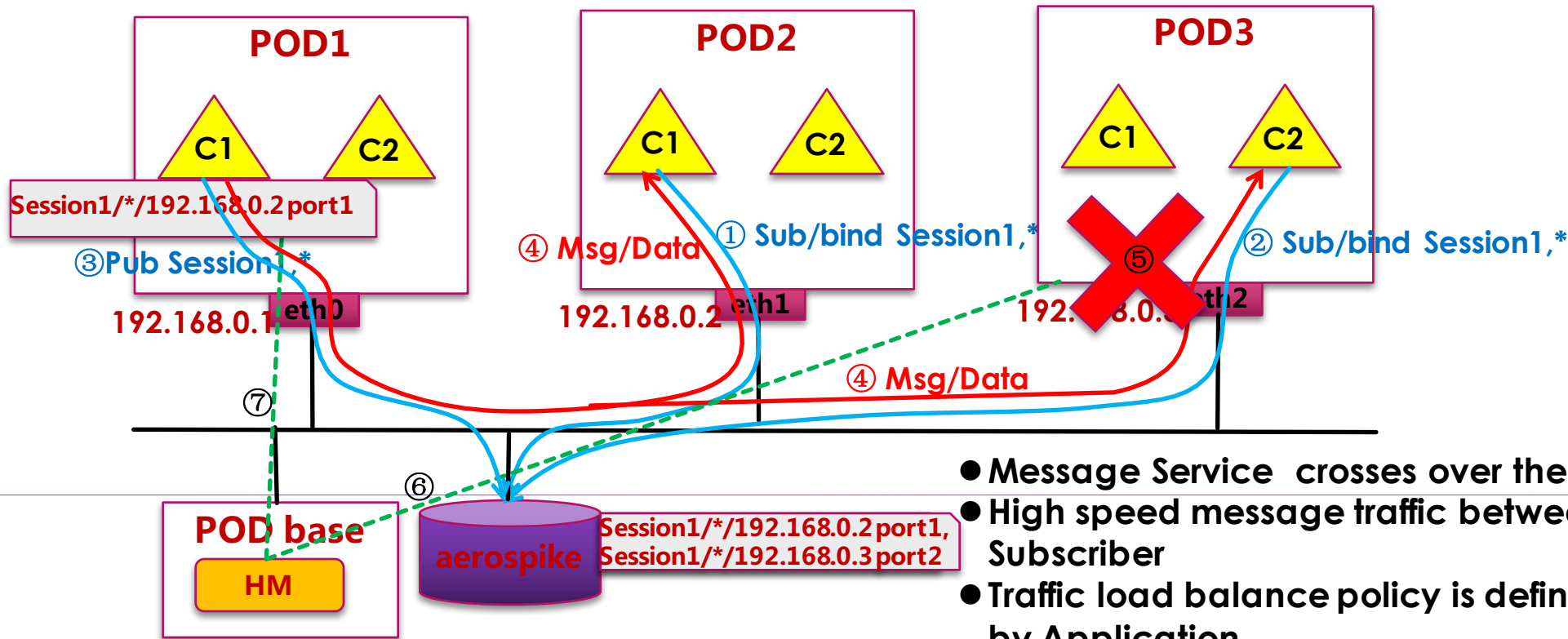

- Message Service crosses over the K8S clusters
- High speed message traffic between Publisher and Subscriber
- Traffic load balance policy is defined on Publisher by Application
- Service will support the conversation HA

Model without DPDK

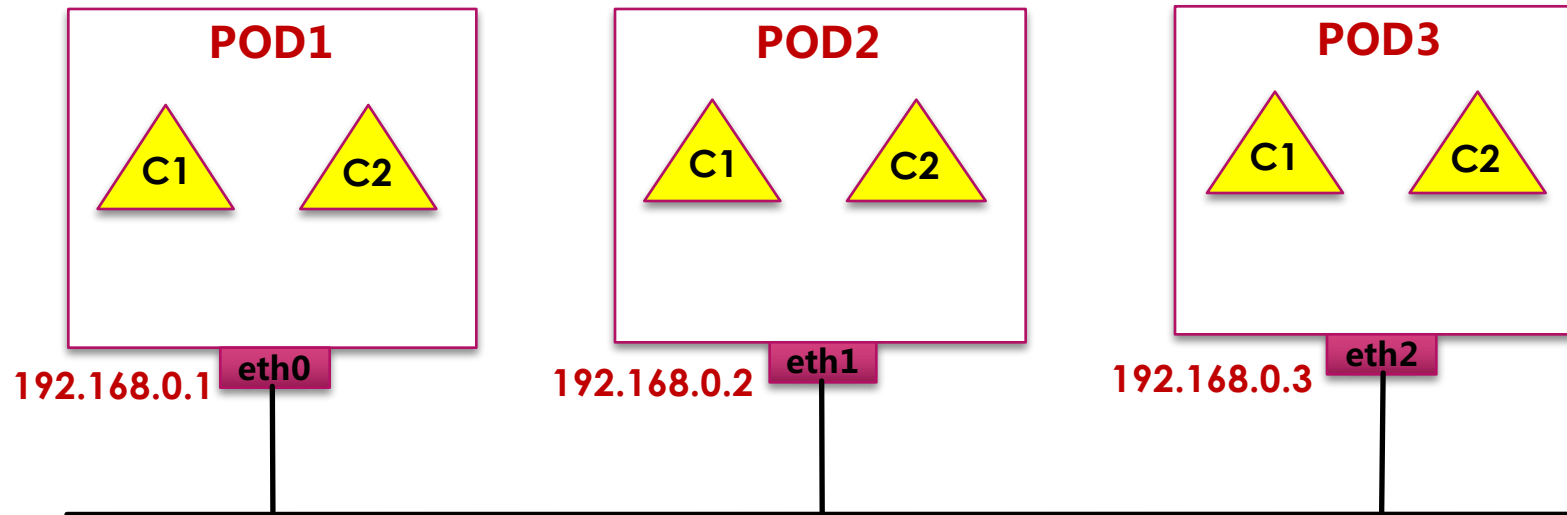

Model with DPDK(1)



- ▶ one DPDK container per Pod

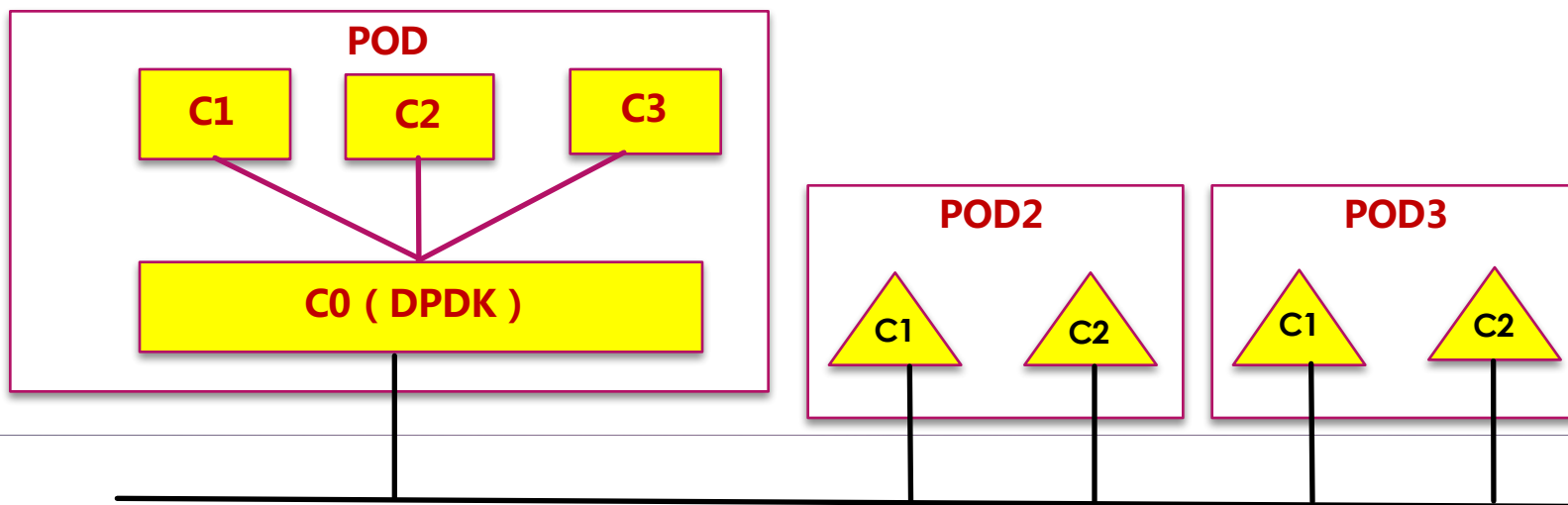

Model with DPDK(2)



- ▶ All pods share a DPDK container

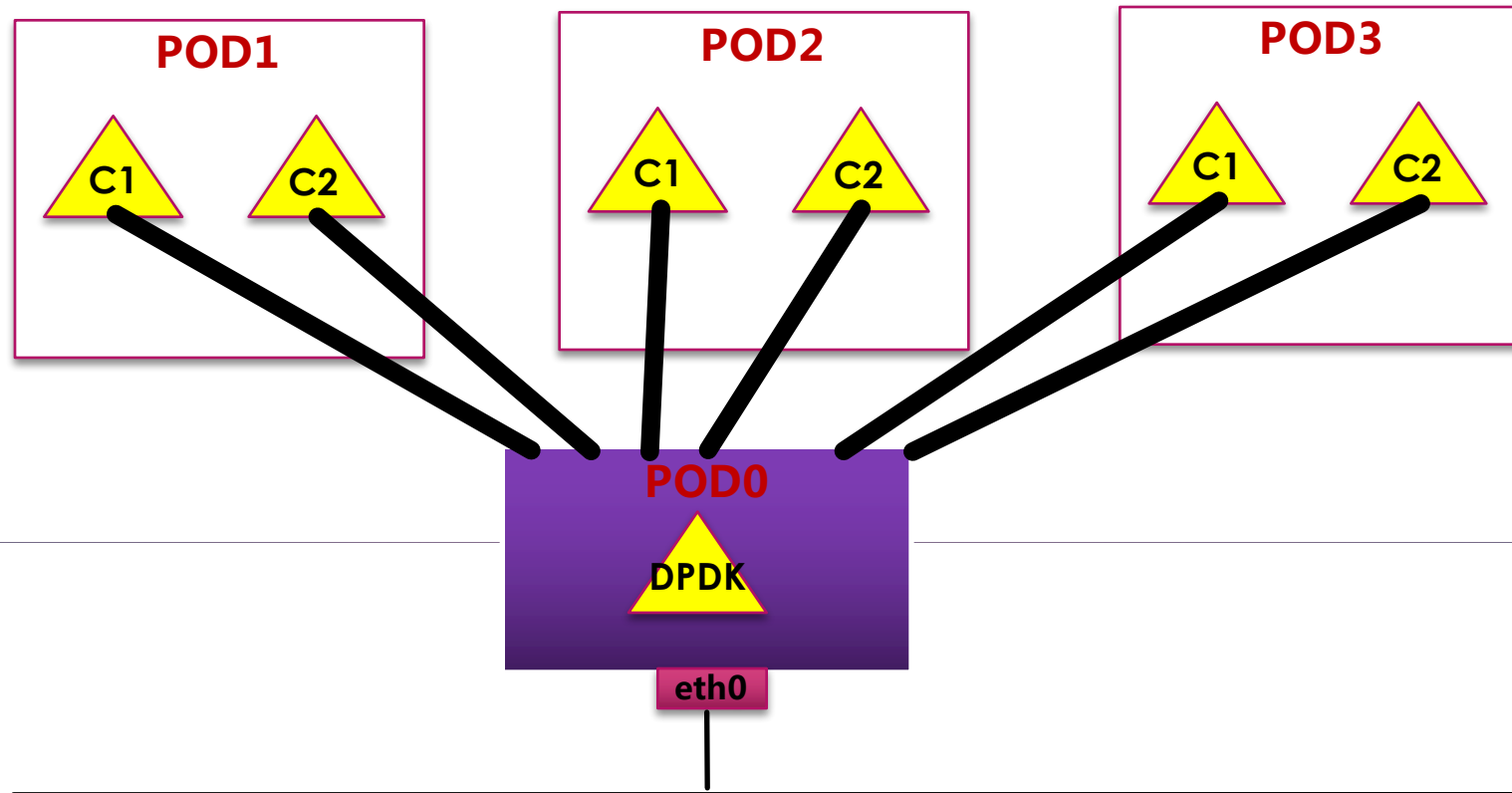

Communications between containers(1)

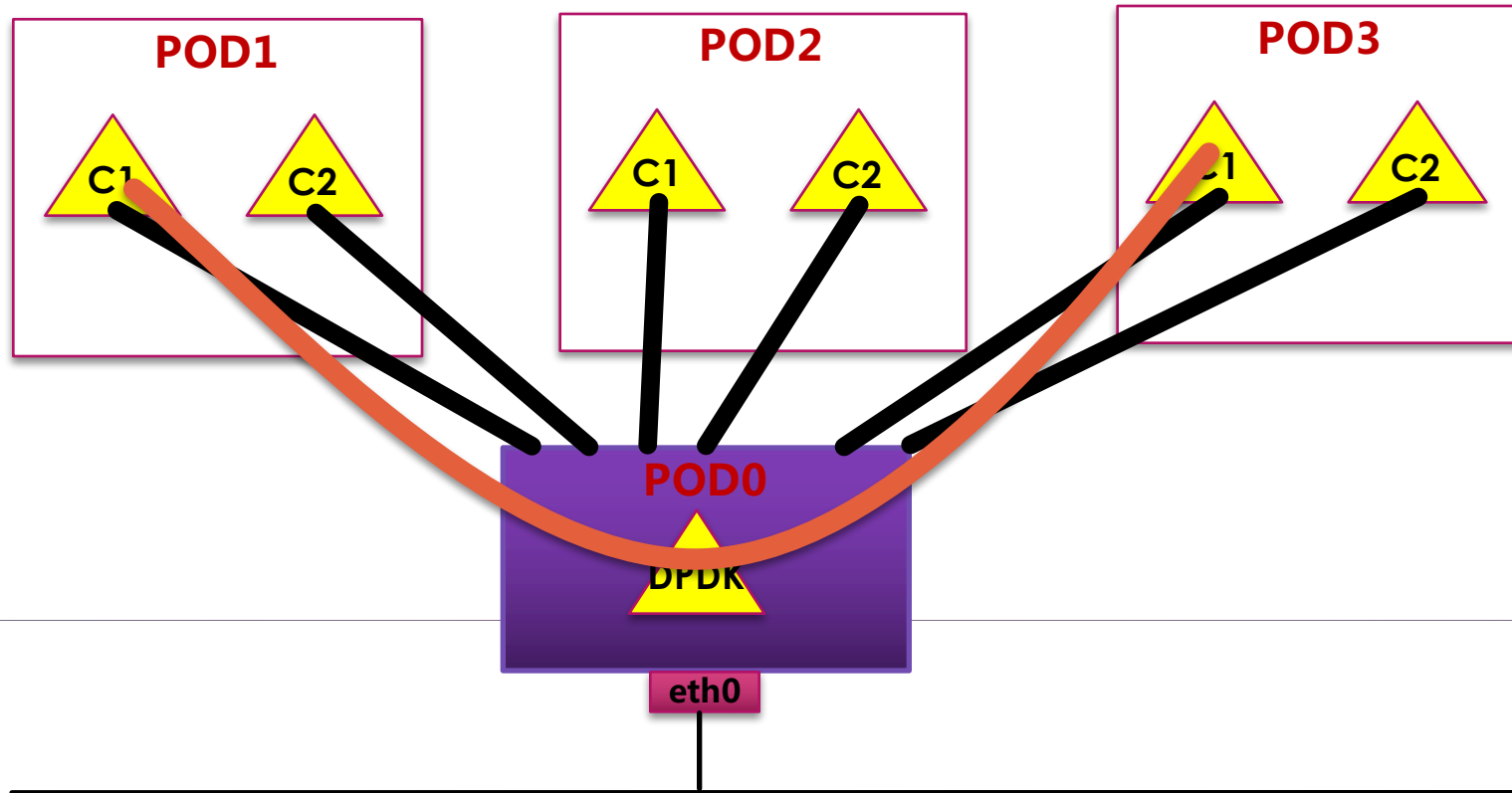

Key Technology



- ▶ master/secondary mechanism
- ▶ sharing memory
- ▶ queue(rte_ring)

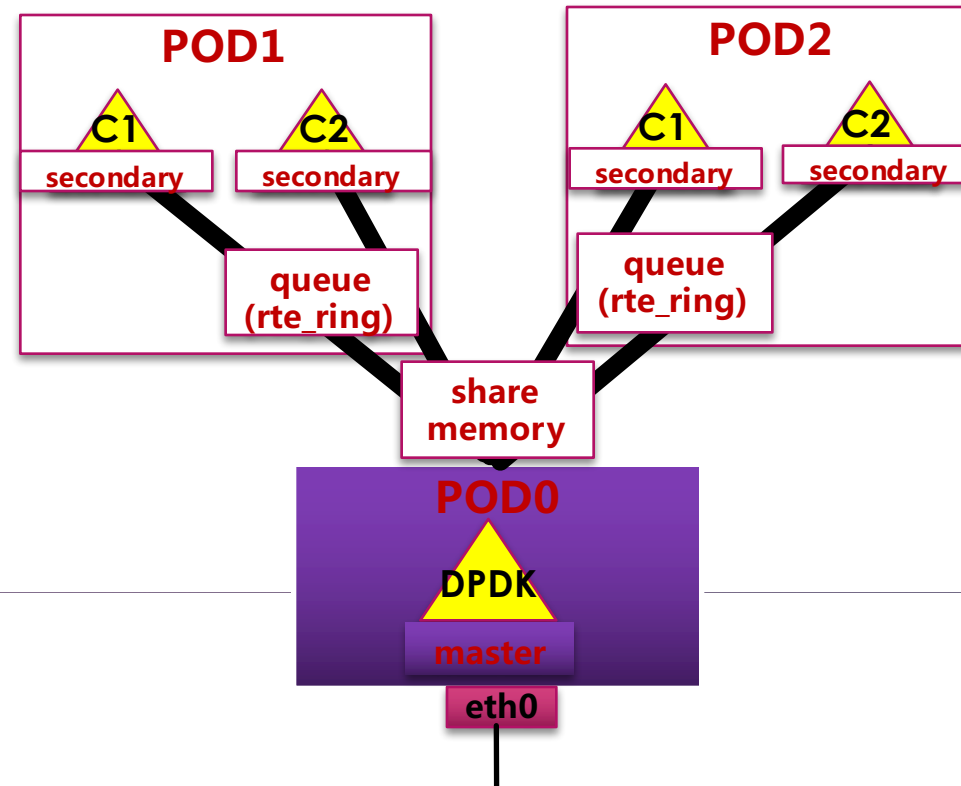

Benefits vs vhost-user



- ▶ Bidirectional zero copy
- ▶ 2M & other size hugepage support
- ▶ vhost-user:
- ▶ only dequeue zero copy
- ▶ only support 1G size hugepage

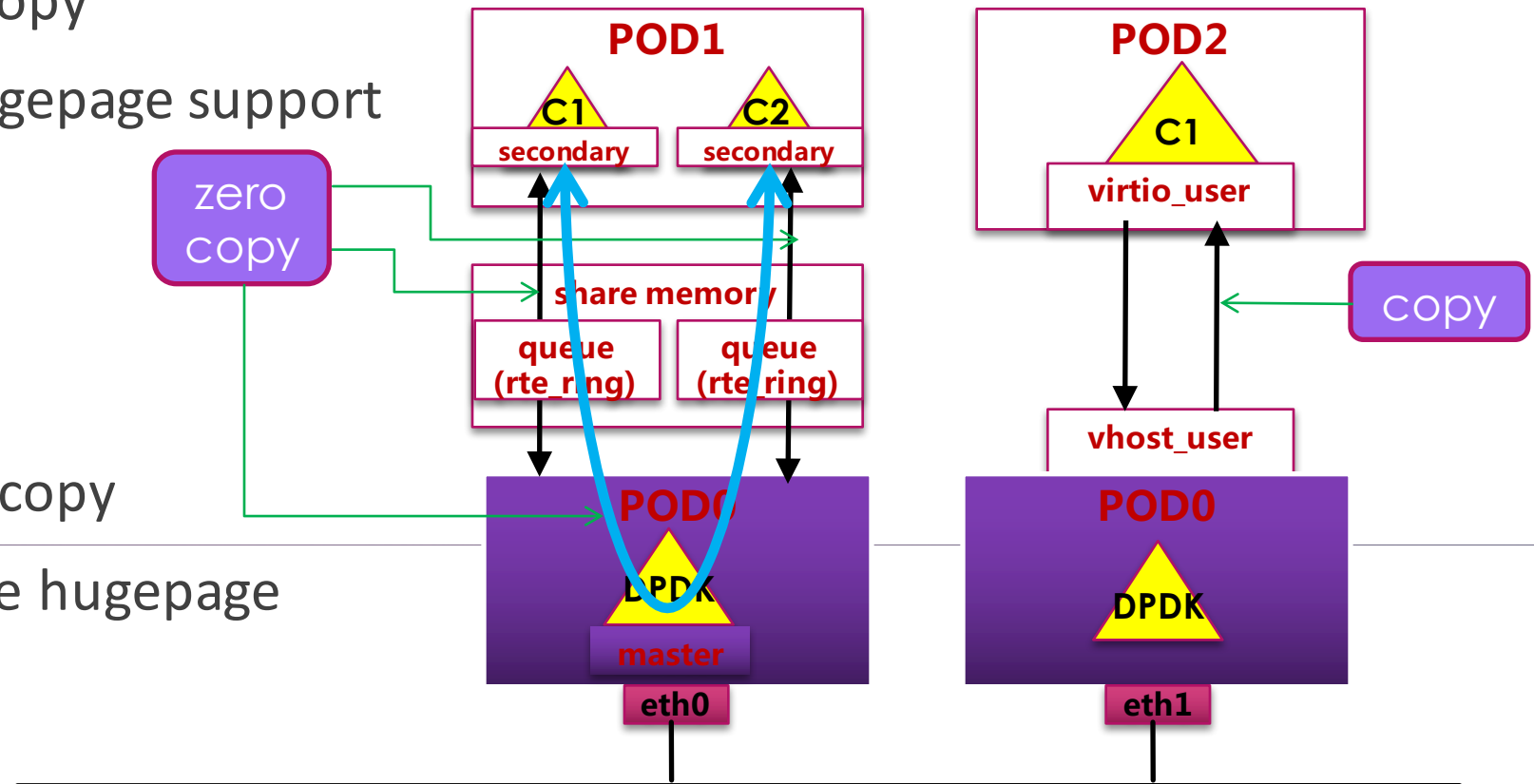

Communications between containers(2)

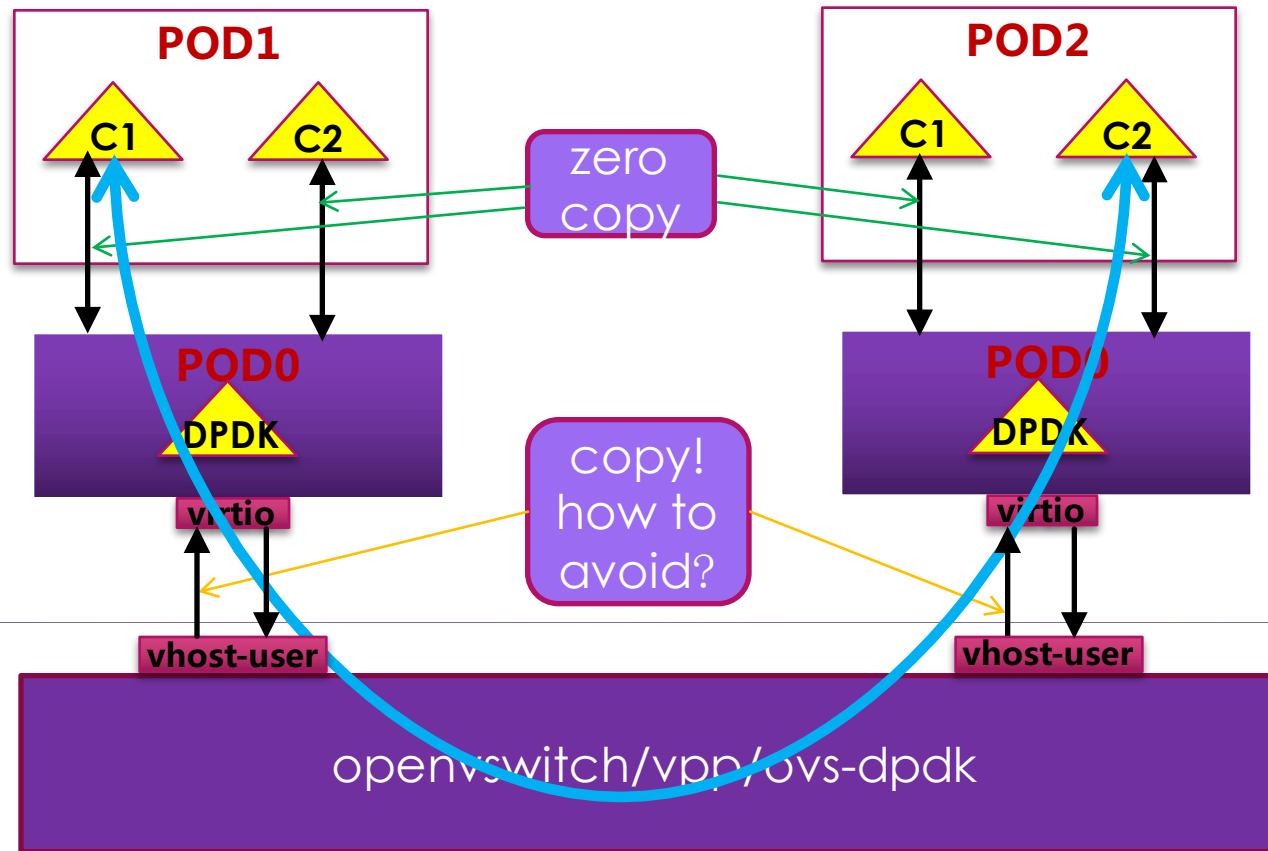

- ▶ combine pod0 with ovs

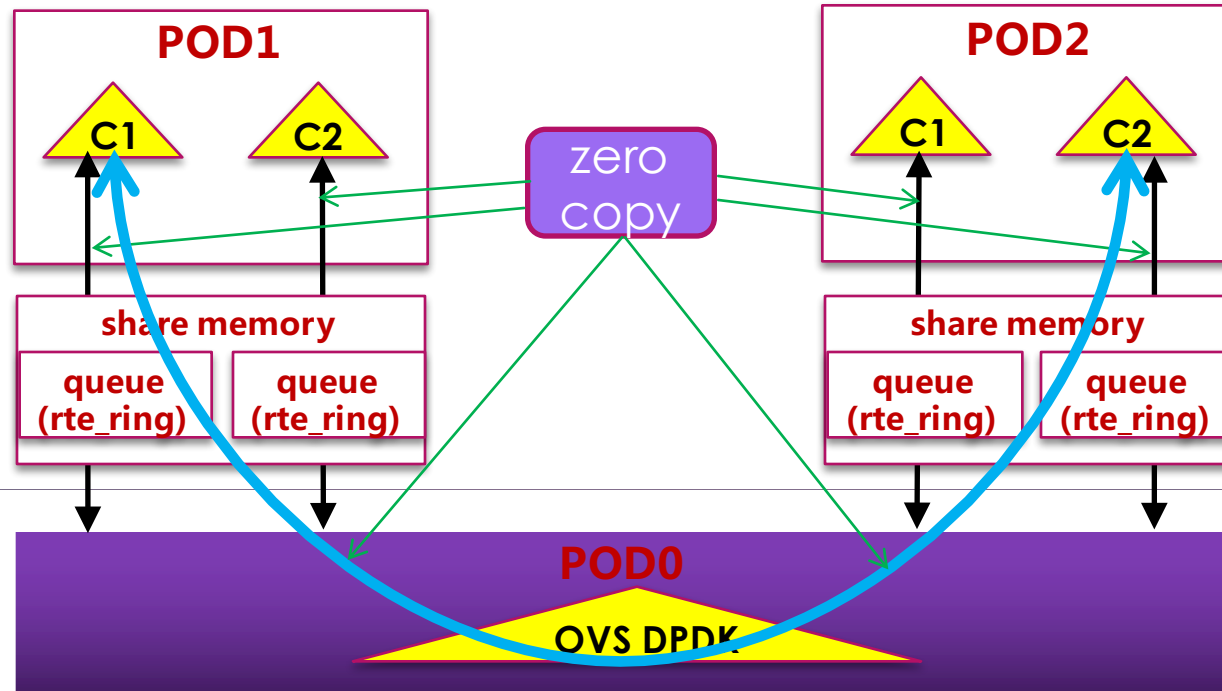

5G and Network Slicing



4G Network: communication service via phones in the communication industry

Communication service (voice, text and Internet)



5G network: all mobile services via all types of devices across all industries

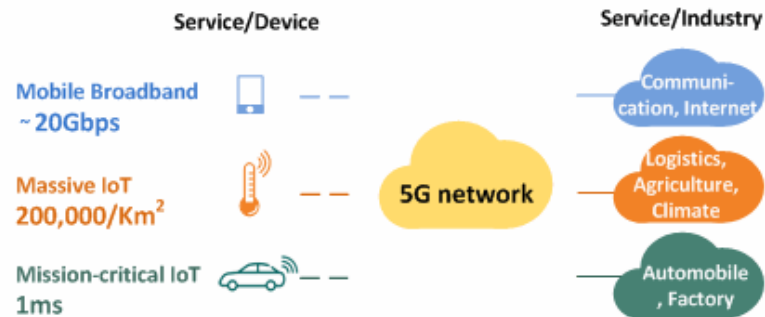

↓ how?

Multiple 5G networks ? X

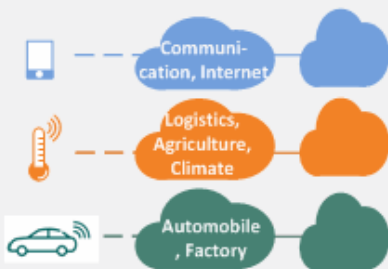

Network Slicing !

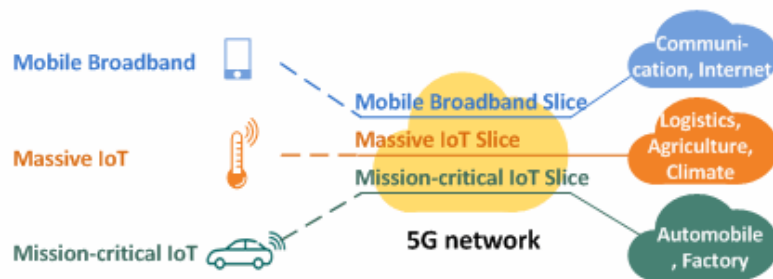

▶ dpdk as microservices brings the following benefits to network slicing:

- ▶ zero copy
- ▶ high performance
- ▶ low latency

Network Slice Orchestration

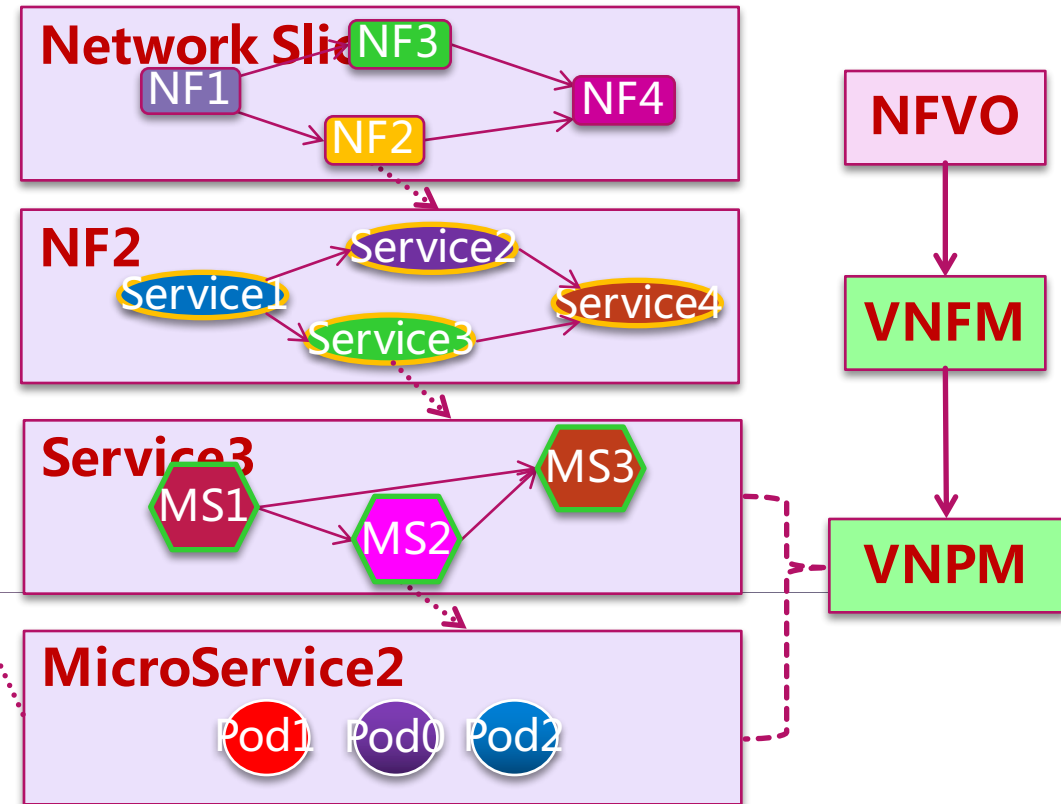
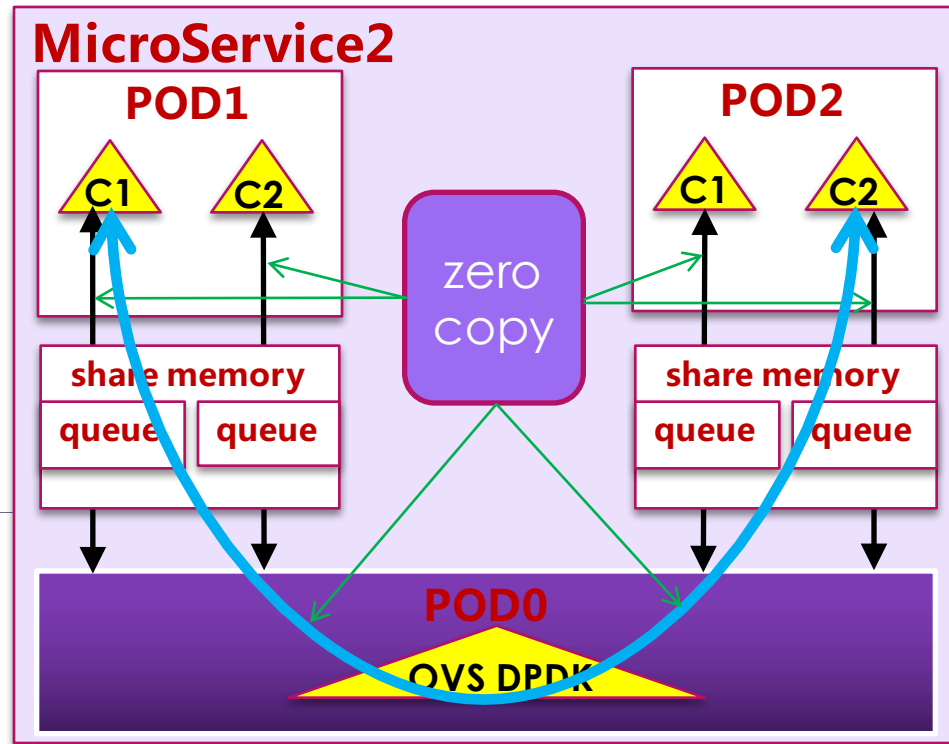

Acknowledge contribution from



- ▶ Chenggang Li
- ▶ Jian Gu
- ▶ Chunhua Qin
- ▶ Songming Yan
- ▶ Binbin Xu